

### Dual Drive

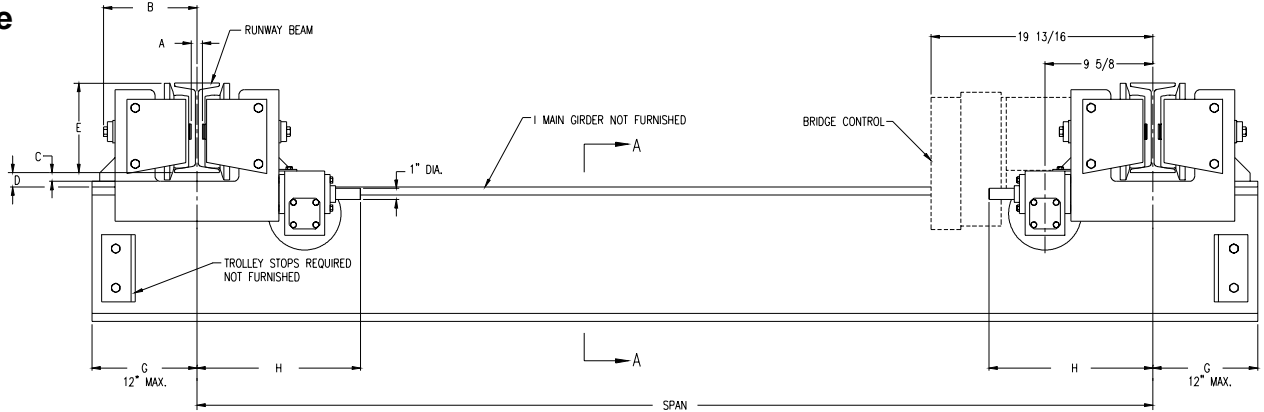

### Single Drive

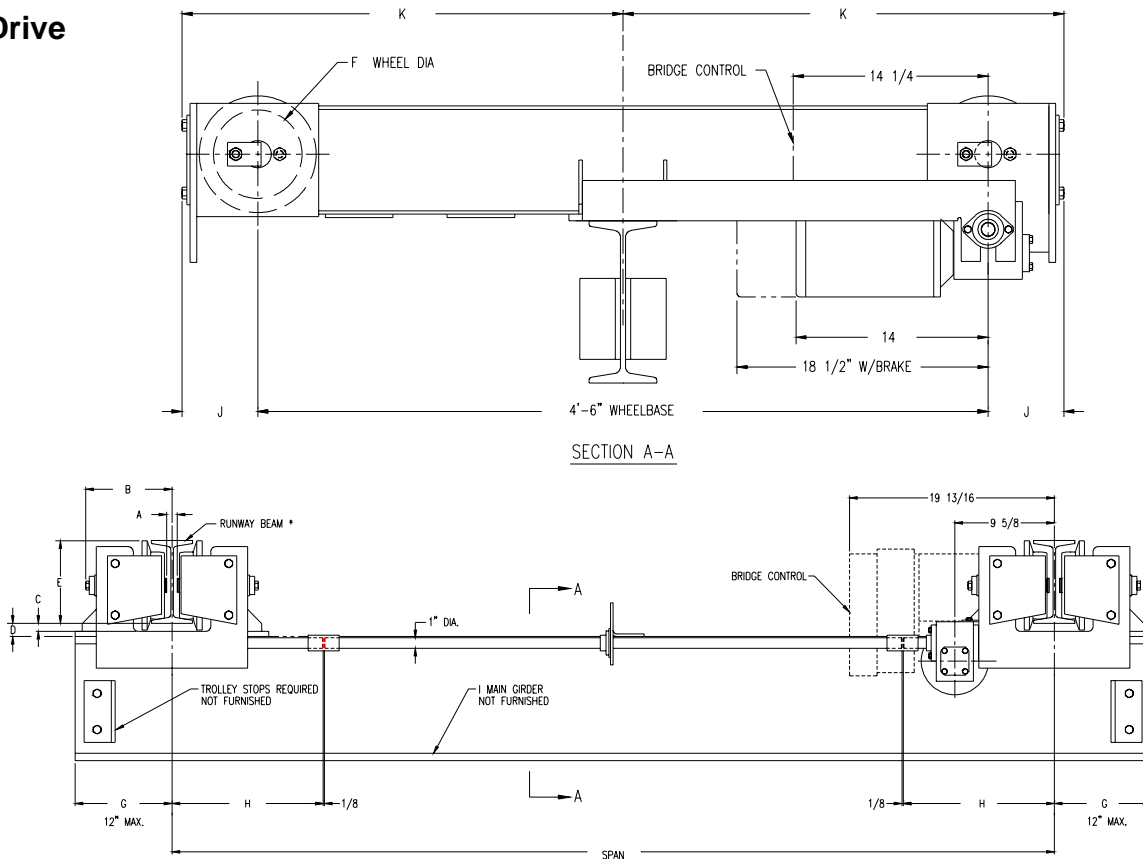

### Clearance Dimensions (in.)

Product Code	Rated Capacity (tons)	* Max. Span (ft)	Runway Beam Sizes**			A	B	C	D	E	F Wheel Dia.	G Min.	H	J†	K	Max. Wheel Load Per Pair (lbs)	Approx. Shipping Wt (lbs)
			Min Beam Width	Min. Flange Width	Max. Flange Width												
905369	1/4 - 3	36	S6x12.5	3-3/8	5-1/2	1-1/8	7-13/16	15/16	1-7/16	5-1/8	4	8-1/4	14	4	2' - 7"	4240	400
905525	5	36	S8x18.4	4	6-1/4	3/4	8-11/16	13/16	1-5/16	8	6-1/2	9-3/8	14-5/8	5-1/2	2' - 8-5/8"	7520	480

\*\*Runway beam sizes shown indicate range of beams that trucks will fit. For proper runway size, consult qualified engineer or architect.  
End trucks for wider flange beams or 3-1/4" patented track are available.

Dimensions A, B, C, D and E are based on minimum beam.

† Dimension with rubber bumpers: 3 ton catalogs 905369 = 7 3/8 and 5 ton catalogs 905525 = 8-7/8.

\* For spans from 36' up to 48' consult factory.